

CORNERSTONE

**Building
Blocks**

Construction Features

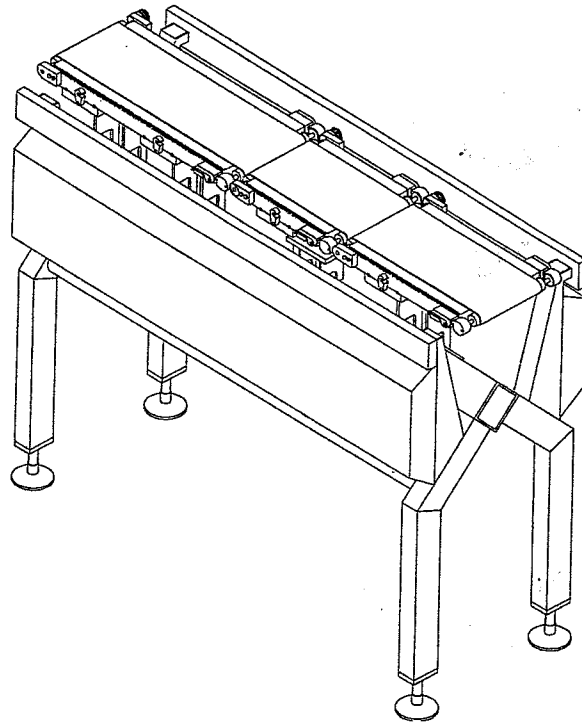

■ **Rugged Welded Steel Frame**

- Patented* Spine Interface System
- Cold rolled steel, painted Steel-It for general applications
- 304 stainless steel for washdown or food grade environments

■ **Easy to Clean Design**

- No food traps, few legs on the floor
- High clearance between the frame and floor

■ **Patented* Belt Conveyor Design**

- Quick release belt systems - no tools required
- Simple belt take-up design
- Solid stainless steel crowned pulleys

■ **Service-factored Power Transmission Design**

- Modular gearmotor drives
- Efficient helical gearing
- Standard IP66 (NEMA 4X) ratings

*Patent Pending

Hi-Speed Checkweigher Systems

A Mettler Toledo Company
5 Barr Rd. Ithaca, NY 14850
800-836-0836 Fax 607-257-6396

BB-CF-1297